

Flanged Process Connection, Diaphragm Seals with Internal Diaphragm Model 990.26

WIKA Data Sheet DS 99.26

Applications

- Chemical process industry
- Petrochemical industry
- Suitable for corrosive, highly viscous, crystallising or hot pressure media
- For small flanged process connections

Special Features

- Open flange with an internal welded diaphragm with contoured diaphragm bed
- No sealing or clamping elements
- Compact design



Diaphragm Seal, Flanged Process Connection Model 990.26
with Pressure Gauge Model 233.50 NS 100

Description

Process connection

Flanges DN 15, 20, 25 following EN 1092-1,
sealing face form B1
or NPS ½", ¾", 1" per ASME B 16.5, RF 125 ... 250 AA

Pressure rating

See table (reverse side)

Suitable pressure ranges

400 mbar and up, depending on diaphragm size and
process conditions

Material of wetted parts

Stainless steel 316L

Instrument connection

Material stainless steel 316L, axial weld-in connection or
adaptor G ½ female per EN 837-1, welded to capillary

Capillary extension

Axial entry capillary of stainless steel 1.4571, welded to
body,
armoured, armour material stainless steel 1.4301
Standard extensions: 1, 1.6, 2.5, 4, 5 m
Minimum curve radius: 30 mm

Optional extras

Process connection

- Sealing faces per EN 1092-1, form B2 or per ASME B 16.5, RF 125 AA, 500 AA (limited for special materials, please inquire)
- Flame arrester approved for Zone 0

Instrument connection

- Adaptor with optional welding or pipe thread nipple
- Gauge adaptor G ½ female for directly mounted gauge
- Various adaptors for directly mounted transmitters
- Cooling tower for directly mounted gauge when fluid temperature > 100 °C

Material of wetted parts

- Stainless steel 1.4435, 1.4541, 1.4571, 1.4462 titanium; Hastelloy B3, C4, C276; Monel 400; nickel Inconel 600; Incoloy 825; tantalum
- PTFE foil max. 260 °C ≤ 100 bar

Capillary extension

- Custom extension lengths between 1 and 10 m
- Soft polyethylene armour

Dimensions in mm

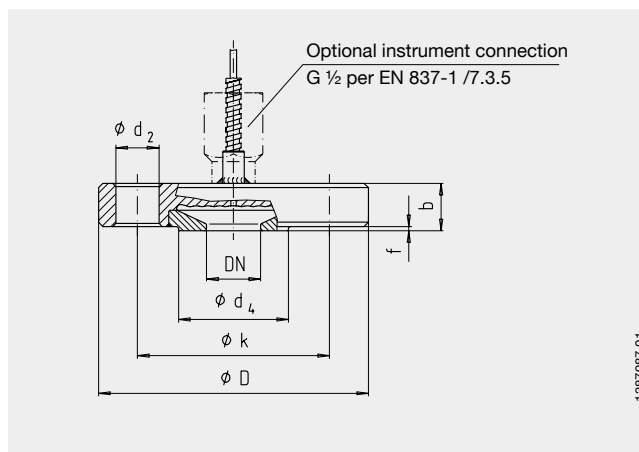

Flange connection following EN 1092-1, form B1

DN in mm	PN in bar	Dimensions in mm					Raised portion			Weight in kg
		Mb	D	b	d ₂	k	f	d ₄	x	
15	10/40	40	95	22	14	65	2	45	4	1.00
20	10/40	40	105	22	14	75	2	58	4	1.30
25	10/40	52	115	22	14	85	2	68	4	1.50

Mb = effective diameter of diaphragm, x = number of drill holes

Flange connection per ASME B 16.5, raised face

NPS	Class	Dimensions in mm					Raised portion			Weight in kg
		Mb	D	b	d ₂	k	f	d ₄	x	
½"	150	32	90	22	16	60.5	2	35	4	1.00
	300	40	95	22	16	66.5	2	35	4	1.00
¾"	150	40	100	22	16	70	2	43	4	1.10
	300	40	120	22	20	82.5	2	43	4	1.60
1"	150	52	110	22	16	79.5	2	51	4	1.40
	300	52	125	22	20	89	2	51	4	1.70

Mb = effective diameter of diaphragm, x = number of drill holes

Ordering information

Model / Process connection (standard, nominal size, pressure rating, sealing face) / Material of wetted parts / Instrument connection: directly combined or capillary extension, capillary length / Fill fluid / Pressure gauge model / Process conditions: application, process temperature max. and min., ambient temperature max. and min.

Modifications may take place and materials specified may be replaced by others without prior notice. Specifications and dimensions given in this leaflet represent the state of engineering at the time of printing.

